



**Your trusted global partner  
in life-saving research.**

For over 50 years, Allentown has provided critical solutions to the biomedical research community. Our high-quality equipment and advanced vivarium systems continue to define and exceed industry standards. Like everything we do, our unparalleled customer service is stamped with the Allentown hallmarks of integrity, dedication and care.

# Guinea Pig

HOUSING



OVERVIEW

Providing critical solutions with integrity and care.



## Long Lasting, Multi-Purpose Housing

The standard non-ventilated and ventilated guinea pig housing designs are based on Allentown's classic housing units and decades of proven caging experience and design expertise.

### Standard and Custom Guinea Pig Housing Solutions –

Allentown's plastic guinea pig caging system provides clean, comfortable and quiet housing for your animals. With a ridged stainless steel frame and rugged plastic cage bases, the Allentown guinea pig system will stand the test of time and provide you with an affordable and reliable solution for your research needs.

**Superior Fabrication Leads to Products That Last a Lifetime –** For 50 years Allentown has been refining its design and manufacturing process to make certain Allentown housing units are the most durable and long lasting on the market today. From materials to craftsmanship, design to testing, delivery to field service, we stand behind the performance and durability of each and every Allentown Guinea Pig unit.

## COMPONENTS



### Rack System

Unibody design reduces noise from animal movement and rack transportation

Heliarc welded tubular frame and removable electropolished front panel

Removable stainless steel front panel and top grid cage covers

76 mm x 127 mm permanent cardholders on cage doors

Food hopper

127 mm diameter stainless steel casters, two with brakes

Stainless steel automatic watering

Bottle watering systems

### Cage System

Cage floor space of 0.4 m<sup>2</sup>

No-tip drawer design allows cage to pull forward simplifying animal removal

Vacuum molded PC + ABS plastic cage is washable up to 90 °C and weighs less than 6.8 kg

Plastic cage body resistant to alkaline and acid detergents

Cages stack for ease of transport and compact storage

Solid floors

**SPECIFICATIONS**

Size	Rack Dimensions				Internal Cage Dimensions			Matrix		Weight <sup>2</sup> kg	Animal Capacity
	Depth (A)	Depth (B)	Width (C)	Height <sup>1</sup> (D)	Depth	Width	Height	Col.	Row		
	mm	mm	mm	mm	mm	mm	mm	Col.	Row		
<b>Guinea Pig</b>											
5	622	725	873	1716	533	734	254	1	5	116	20
10	622	744	1721	1716	533	734	254	2	5	195	40

<sup>1</sup> Height includes casters <sup>2</sup> All weights are approximations

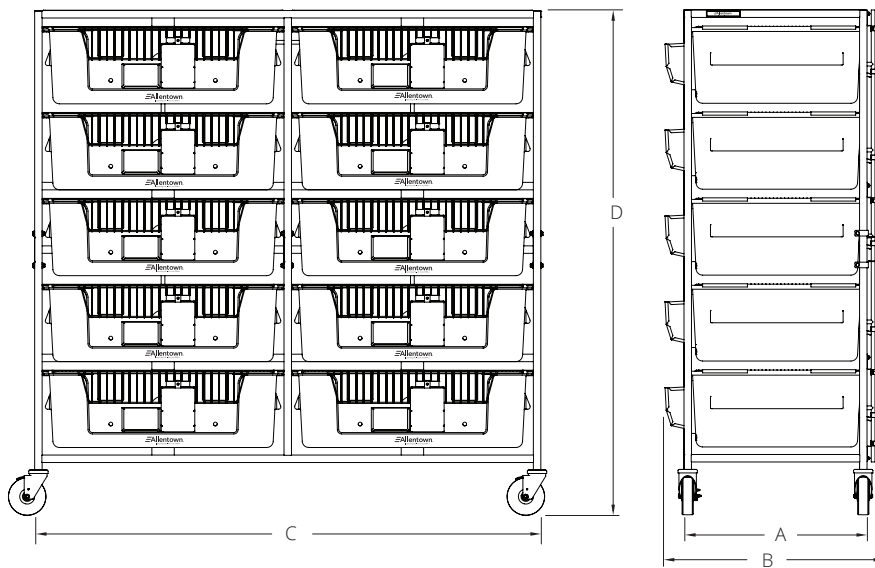

**OVERVIEW – VENTILATED SYSTEM: NEXGEN 1800**

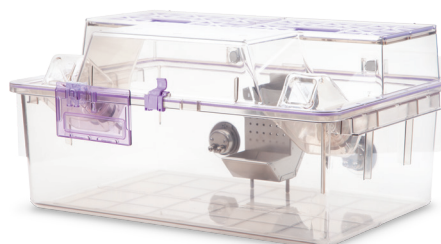

**IVC System**

- Positive or negative precision air controlled rack
- Exhaust plenum always negative to the room
- 10, 15, 20, and 30 cage capacities available
- Whole rack system and cages are autoclavable up to 134 °C<sup>1</sup> and chemically sterilisable
- Plastic (polysulfone) cage support runners with integrated spring-operated cage lock with docking indicator
- Ergonomic, single-finger motion docking with auto-locking feature
- Multi-directional 127 mm diameter stainless steel casters with gray polypropylene wheels with sealed ball bearings and four foot-operated brakes
- Dismantable horizontal airflow manifolds with tethered dual plastic end caps for ease of cleaning
- Rear exhaust and supply plenum configurations for single-sided IVCs, or same side exhaust and supply plenum configurations for double-sided IVCs
- 100 mm diameter vertical supply and 100 mm diameter vertical exhaust plenums with back and bottom door access
- 304 stainless steel, welded frame construction, utilizing both square and rectangular structural tubing
- Cage air tubes are 304 stainless steel
- Automatic watering available
- Row and column identification labels
- Model number and serial number identification labels
- Compatible with all configurations of EcoFlo™ blowers
- Compatible with WiVarium Plus™ and Wi-Com Vantage™
- Compatible with Sentinel™ EAD® and Sentinel2™ Colony Health Monitoring systems
- Compatible with Wi-Com Sensus™ RFID census solution

**Cage System**

- Cage floor space of 1800 cm<sup>2</sup>
- Cage height of 254 mm, plus multiple enrichment options, permits bipedal posture and animal enrichment
- Unobstructed views into and out of cage
- Wider, more ergonomic design for balanced weight distribution during handling
- Ergonomic handles on side of cage for ease of handling
- Clear polysulfone plastic
- Gasketed cage lid ensures safety and protection from damage
- Clear cage and flip-up / stay-up cardholders improve observations
- Easily accessible water bottles (EBT)
- Hinged filter retainer swings up for easy filter replacements
- Compact nesting and stacking for more efficient autoclaving throughput
- Available with or without locks and with multiple feeder configurations

**COMPONENTS – VENTILATED SYSTEM: NEXGEN 1800**

**Cage System with Hanging Feeder**  
588 mm x 286 mm x 412 mm  
Floor space: 1800 cm<sup>2</sup>

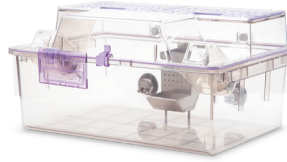

**Bottle**



480 mL (filled)  
Item # PC16BHT (bottle)  
Item # SPL48RS-18 (spin-on lid)

**Top**

**External Bottle Top**  
Optional Filter Guard available  
572 mm x 171 mm x 410 mm | 1860 g  
Item # 230347-1 (without locks)  
Item # 230347-2 (with locks)



**Cardholder**



**76 mm x 102 mm Vertical**  
Item # VH34P9-8  
(also available in 76 mm x 127 mm  
Item # VH35P9-8)



**76 mm x 102 mm Horizontal**  
Item # HH34P9-8  
(also available in 76 mm x 127 mm  
Item # HH35P9-8)

**WBL / Feeder**



**Hanging Feeder: Guinea Pig**  
Food capacity: 998 g  
89 mm x 183 mm x 140 mm  
381 g | Item #: 228542



**Hanging Feeder: Guinea Pig/Ferret**  
Food capacity: 1202 g  
129 mm x 185 mm x 107 mm  
653 g | Item #: 228560

**Cage**

**Cage**  
588 mm x 194 mm x 395 mm | 2449 g  
Item # 315351-1 (without automatic watering)  
Item # 315351-2 (with automatic watering)



**SPECIFICATIONS – VENTILATED SYSTEM: NEXGEN 1800**

Size	Depth (A)	Width (B)	Height <sup>1</sup> (C)	Height <sup>1,2</sup> (D)	Matrix		Weights <sup>3</sup> (loaded)	Weights <sup>3</sup> (unloaded)	Animal Capacity	ACH	Supply Air m <sup>3</sup> /hr	Exhaust Air (+) m <sup>3</sup> /hr	Exhaust Air (-) m <sup>3</sup> /hr	Energy Use Watts	Heat Load Watts	
	mm	mm	mm	mm	Col.	Row										
<b>127 mm Casters</b>																
10	622	1283	1697	1727	2	5	1	191	93	30	60	23.8	18.7	30.6	20.5	18.5
15	622	1882	1697	1727	3	5	1	200	96	45	60	37.4	28.9	47.6	21.4	19.3
20	889	1389	1697	1727	2	5	2	231	113	60	60	49.3	37.4	61.2	27.3	24.6
30	889	1988	1697	1727	3	5	2	286	136	90	50	61.2	45.9	76.5	29.1	26.2

Note: a.) Airflow at sea-level b.) Rack weight without blowers, animals, bedding or watering c.) Airflow tolerance ± 10 % d.) Other configurations available.  
<sup>1</sup> Height includes casters. Add 247 mm to 297 mm for rack mounted blowers <sup>2</sup> Height includes removable runners and collars <sup>3</sup> All weights are approximations

**Notes**

Ergonomic handles on side of cage for ease of handling

Optional top panel

Optional bumpers may change dimensions

Multiple blower configurations

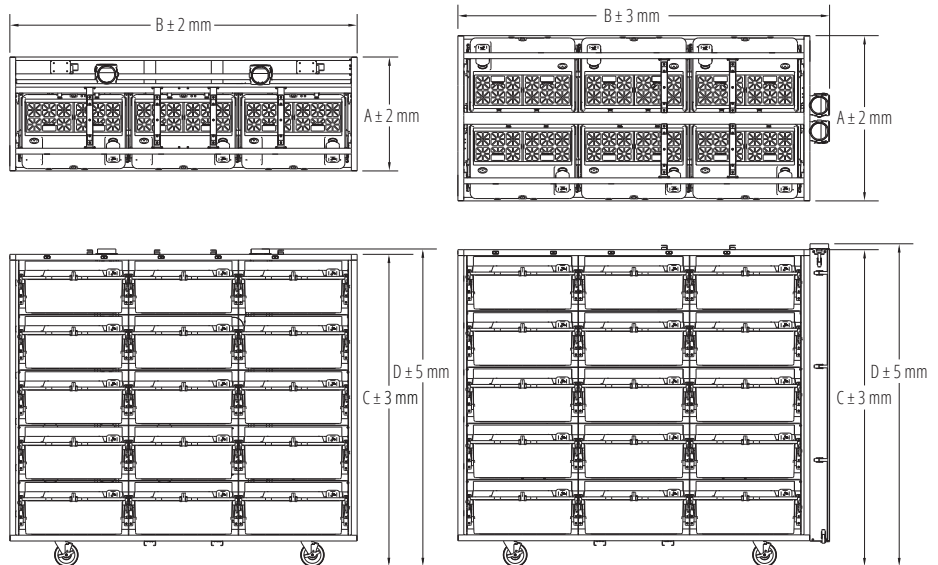

## SPECIFICATIONS – VENTILATED SYSTEM: NEXGEN 1800

### External Dimensions

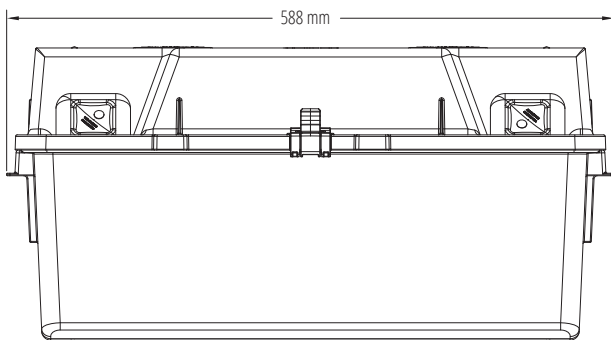
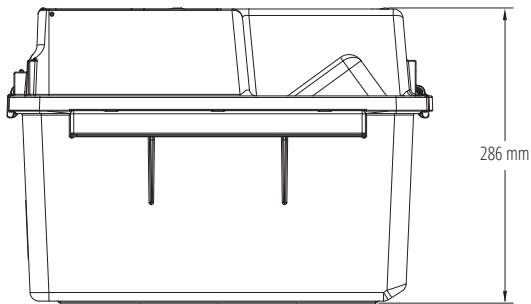
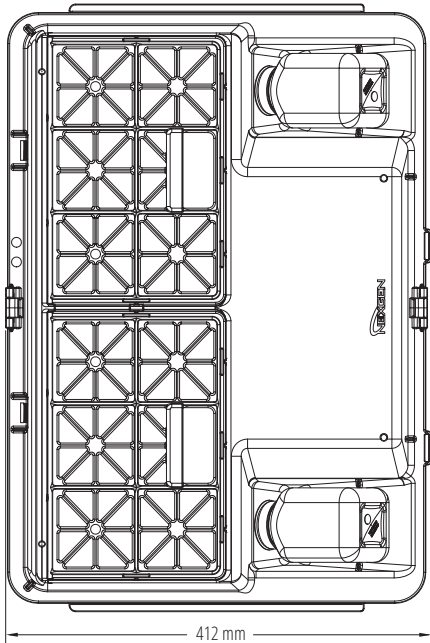

### Internal Dimensions

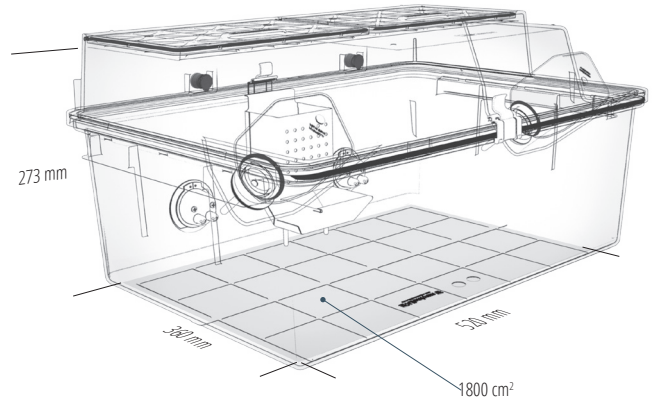

**SPECIFICATIONS – VENTILATED SYSTEM: NEXGEN 1800**

**External Bottle Top**

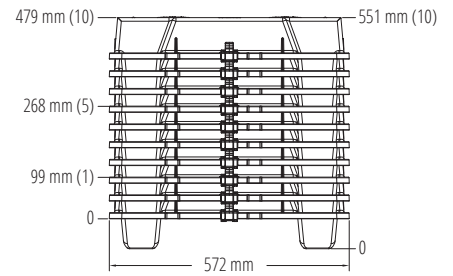
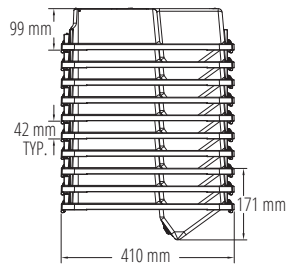
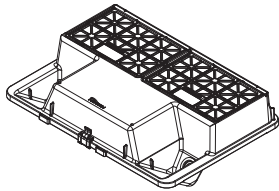

**Cage**

